



www.bdsensors.com

BA_XMD_EX_E_SRO

Headquarter Eastern Europe

BD SENSORS s.r.o.
Hradištská 817
CZ - 687 08 Buchovice
Czech Republic
Tel.: +420 572 411 011
Fax: +420 572 411 497

Headquarter Western Europe / International

BD SENSORS GmbH
BD-Sensors-Str. 1
D - 95199 Thierstein
Germany
Tel.: +49 (0) 92 53 / 98 11-0
Fax: +49 (0) 92 53 / 98 11-11

Russia

BD SENSORS RUS
39a, Varshavskoe shosse
RU - Moscow 117105
Russia
Tel: +7 (0) 9 59 81 / 09 63
Fax: +7 (0) 9 57 95 / 07 21

further agencies in:**EUROPE**

- Belgium
- Denmark
- Finland
- France
- Great Britain
- Greece
- Italy
- Lithuania
- Luxembourg
- Netherlands
- Norway
- Poland
- Portugal

- Romania
- Sweden
- Switzerland
- Slovakia
- Spain
- Turkey
- UK
- Ukraine

AFRICA

- Egypt
- South Africa

ASIA

- India
- Iran
- Israel
- Japan
- Kazakhstan
- Malaysia
- Singapore
- Taiwan
- Thailand
- Vietnam

AUSTRALIA

The addresses of our distribution partners are listed on our homepage www.bdsensors.com. It is possible to download data sheets, operating manuals, ordering codes and certificates, as well.

Table of contents

- General information
- Product identification
- Mechanical installation
- HART[®] communication
- Special regulations for IS-areas
- Electrical Installation
- Initial start-up
- Operation
- Error handling
- Placing out of service
- Maintenance
- Service / Repair
- Disposal
- Warranty conditions
- Declaration of conformity / CE

1. General information**1.1 Information on the operating manual**

This operating manual contains important information on proper usage of the device. Read this operating manual carefully before installing and starting up the pressure measuring device.

Adhere to the safety notes and operating instructions which are given in the operating manual. Additionally applicable regulations regarding occupational safety, accident prevention as well as national installation standards and engineering rules must be complied with!

For the installation, maintenance and cleaning of the device, you must absolutely observe the relevant regulations and stipulations on explosion protection (VDE 0160, VDE 0165 or EN 60079-14) as well as the occupational safety provisions. The device was constructed acc. to standards EN 60079-0:2012, EN 60079-11:2012, EN 60079-26:2015. This operating manual is part of the device, must be kept nearest its location, always accessible to all employees.

This operating manual is copyrighted. The contents of this operating manual reflect the version available at the time of printing. It has been issued to our best knowledge. However, errors may have occurred. BD SENSORS is not liable for any incorrect statements and their effects.

– Technical modifications reserved –

1.2 Symbols used

 **DANGER!** – dangerous situation, which may result in death or serious injuries

 **WARNING!** – potentially dangerous situation, which may result in death or serious injuries

 **CAUTION!** – potentially dangerous situation, which may result in minor injuries

 **CAUTION!** – potentially dangerous situation, which may result in physical damage

 **NOTE** – tips and information to ensure a failure free operation

1.3 Target group

 **WARNING!** To avoid operator hazards and damages of the device, the following instructions have to be worked out by qualified technical personnel.

1.4 Limitation of liability

By non-observance of the operating manual, inappropriate use, modification or damage, no liability is assumed and warranty claims will be excluded.

1.5 Intended use

The **Differential Pressure Transmitter XMD** has been especially designed for the process industry and can be used for level measurement of closed, pressurized tanks, pump or filter controlling, etc. The transmitter is as a standard equipped with HART[®]-communication and the parameterisation can be done via PC, HART[®]-communicator, etc.

This operating manual applies to devices with explosion protection approval and is intended for the use in IS-areas. A device has an explosion protection approval if this has been specified in the purchase order and confirmed in our order confirmation. In addition, the manufacturing label contains the -symbol.

It is the operator's responsibility to check and verify the suitability of the device for the intended application. In addition it has to be ensured, that the medium is compatible with the media wetted parts. If any doubts remain, please contact our sales department in order to ensure proper usage. BD SENSORS is not liable for any incorrect selections and their effects!

The technical data listed in the current data sheet are engaging and must be complied with. If the data sheet is not available, please order or download it from our homepage. (<http://www.bdsensors.com/products/download/datasheets>)

 **WARNING!** Danger through improper usage!

1.6 Safety technical maximum values**1.6.1 Intrinsically safe version**

AX2-XMD: IBExU05ATEX1105 X

permissible temperatures for environment:

application in zone 0 (p_{atm} 0.8 bar up to 1.1 bar):

-20 ... 60 °C

application in zone 1 and 2: -40 ... 70 °C

supply and signal circuit:

U_i = 28 V, I_i = 98 mA, P_i = 680 mW, C_i ≈ 0 nF, L_i ≈ 0 µH

plus cable inductivity 1 µH/m and cable capacity 160 pF/m (for cable by factory)

The internal capacity of supply connections compared to the housing is max. 27 nF

 **NOTE** - The limit values are valid only for the devices with own-sure circuits!

1.6.2. Special conditions

The equipment designed with connector have to be installed in such a way, that the Degree of protection IP20 always will be kept.

The safety and assembly notes contained in the operating instructions and the Ambient temperature range from -40 °C to +70 °C have to be observed.

At pressure transmitter with the marking category ½ equipment, the sensor diaphragm serves as partition wall and has to be protected against mechanical damages.

The isolation of the intrinsically circuit opposite the case is because of leakage flows in the blocking capacitors from the EMV-boards fitted.

1.6.3 Flameproof enclosure

AX7-XMD: IBExU 12 ATEX 1073 X

zone 1: II 2G Ex d IIC T5 Gb

permissible temperatures: -20 ... 70 °C

 **NOTE** – The use of the devices with flameproof enclosure is not allowed in the areas of dust!

1.7 Package contents

Please verify that all listed parts are included in the delivery and check for consistency specified in your order:

- differential pressure transmitter
- protective cap
- this operating manual

1.6.4. Special conditions for safe use

The pressure transmitters type AX7-XMP i, AX7-XMP ci and AX7-XMD can be used in an ambient temperature range from -20°C up to +70 °C.

The cable entry (M20x1.5) supplied by the manufacturer may be used only for fixed installation. The operating company has to ensure an appropriate clamping.

2. Product identification

The device can be identified by its manufacturing labels. It provides the most important data. By the ordering code the product can be clearly identified.

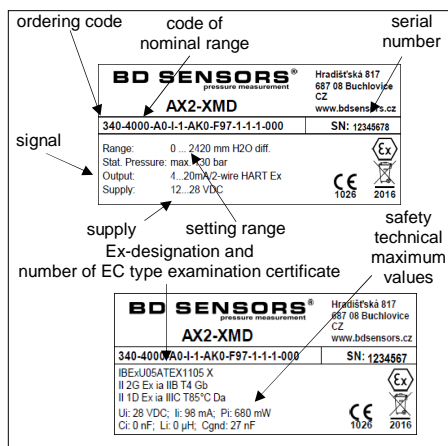





Fig. 1 manufacturing labels – for AX2

 The manufacturing labels must not be removed from the device!

3. Mechanical installation**3.1 Mounting and safety instructions**

 **WARNING!** Install the device only when depressurized and currentless!

 **WARNING!** This device may only be installed by qualified technical personnel who has read and understood the operating manual!

 **DANGER!** Caused by the explosion hazard following instructions have to be complied with:

The technical data listed in the EC type-examination certificate are engaging and must absolutely be complied with. If the certificate is not available, please order or download it from our homepage: <http://www.bdsensors.com/products/download/certificates>

Working on supplied (active) parts, except for intrinsically safe circuits, is principally prohibited during an explosion hazard.

Make sure that an equipotential bonding is in place for the entire course of the line, both inside and outside the intrinsic area.

In case of increased danger of lightning strike or damage by overvoltage, a stronger lightning protection should be planned.

Observe the limiting values specified in the EC type-examination certificate. (Capacitance and inductance of the connection cable are not included in the values.)

Make sure that the entire interconnection of intrinsically safe components remains intrinsically safe. The operator is responsible for the intrinsic safety of the overall system (installation of intrinsic parts).

Do not mount the device in a pneumatic flow rate!

Excessive dust deposits (over 5 mm) and a complete dust covering must be avoided!

When installing the device, at least the ingress protection IP 20 must be realised.

 Handle this high-sensitive electronic precision measuring device with care, both in packed and unpacked condition!

There are no modifications/changes to be made on the device.

 Do not throw the package/device!

To avoid damaging the diaphragm, remove packaging and protective cap directly before starting assembly. The delivered protective cap has to be stored!

Place the protective cap on the pressure port again immediately after disassembling.

Handle the unprotected diaphragm very carefully - it is very sensitive and may be easily damaged.

Do not use any force when installing the device to prevent damage of the device and the plant!

For installations outdoor and in damp areas following these instructions:

- To prevent moisture admission in the plug the device should be installed electrically after mounting, at once. Otherwise a moisture admission has to be blocked e.g. by using a suitable protection cap. (The ingress protection in the data sheet is valid for the connected device.)

- Choose an assembly position, which allows the flow-off of splashed water and condensation. Avoid permanent fluid at sealing surfaces!

- When using a device with cable outlet, turn the outgoing cable downwards. If the cable has to be turned upwards, then point it downward so the moisture can drain.

Install the device in such a way that it is protected from direct solar irradiation. Direct solar irradiation can lead to the permissible operating temperature being overstepped in the worst case. This is prohibited for applications in IS-areas!

 When installing the device to the pressurized system, the operator has to ensure the correct sealing.

 Check the intended resp. delivered seal for compatibility with the medium. If there is no compatibility, take a suitable seal.

 Take note that no assembly stress occurs at the pressure port, since this may cause a shifting of the characteristic curve. This is especially important for very small pressure ranges as well as for devices with a pressure port made of plastic.

 In hydraulic systems, position the device in such a way that the pressure port points upward (ventilation).

 Provide a cooling line when using the device in steam piping.

3.2 General installation steps

- Carefully remove the pressure measuring device from the package and dispose of the package properly.
- Go ahead as detailed in the specific instructions below.

3.3 Installation steps for NPT connections

- Use a suitable seal, corresponding to the medium and the pressure input (e. g. a PTFE-strip).
- Screw the device into the corresponding thread by hand.
- Tighten it with a wrench (for 1/2" NPT: approx. 70 Nm).

3.4 Positioning of the display and operating module

The display and operating module is continuously rotatable so that clear readability is guaranteed even in unusual installation positions. To change the position go ahead as follows:

- Screw off the metal cap by hand.
- Turn the display and operating module carefully into the desired position by hand. The module is equipped with a rotational limiter.

Before screwing on the cap again, the o-ring and sealing surfaces of the housing have to be checked for damage and if necessary have to be changed!

Afterwards screw the metal cap on by hand and make sure that the housing is firmly locked again.

 **WARNING!** It is prohibited to open and configure the devices in the presence of explosion hazards. Therefore it is recommended to position the display and operating module together with the mechanical installation.

Pay attention that no moisture can enter the device. Moreover, the seals and the sealing surfaces should not get dirty, as this may cause a reduction of the degree of protection depending on the case of application or place of installation. This can lead to a breakdown of the devices or to irreparable damages on the device.

4. HART[®] communication

 **DANGER!** It is prohibited to interrupt the intrinsically safe circuit in the presence of explosion hazards in order to loop in a HART[®] communication interface (HART[®]-communicator or HART[®]-modem).

The analogue output signal is overridden by an additional signal according to the HART[®]-specification. The device can be configured via a HART[®]-communication device. Therefore we suggest our programming kit CIS 150 (available as accessory).

To ensure a trouble-free operation the following requirements should be fulfilled:

maximal cable length between device and power supply:

$$L_{\max} = \frac{65 \cdot 10^9}{R_v \cdot C_v} - \frac{40 \cdot 10^9}{C_v}$$

whereas L_{max}: maximum length of cable in [m]
R_v: resistance of the cable together with the load resistance in [Ω]
C_v: capacity of the cable in [pF/m]

resistance R:

$$R = \frac{U - 12}{0,024} \Omega$$

whereas U: power supply in [V_{DC}]

The resistance must be at least 240 Ω.

5. Special regulations for IS-areas**5.1 Protection against electrostatic charge hazards**

Different types of the device partially consist of chargeable plastic components. These are in particular coating of the housing as well as the plastic pressure port (optionally). A potential electrostatic charge presents the danger of spark generation and ignition. An electrostatic charge must therefore be absolutely prevented.

 Generally, a shielded cable must be used.

 Avoid friction on the plastic surfaces!

 Do not clean the device dry! Use, for example, a damp cloth.

The following warning sign is, if applicable, attached to the device. It points once more to the hazard of electrostatic charging.

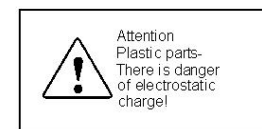



Fig. 2 warning sign

 The warning sign must not be removed from the device!

5.2 Overvoltage protection

If the device is used as electrical equipment of category 1 G, a suitable overvoltage protection device must be connected in series (attend the valid regulations for operating safety as well as EN60079-14).

5.3 Schematic circuit

The operation of an intrinsically safe transmitter in intrinsic safe areas requires special care when selecting the necessary Zener barrier or transmitter repeater devices to allow the utilization of the device's properties to the full extent.

The following diagram shows a typical arrangement of power supply, Zener barrier and pressure transmitter.

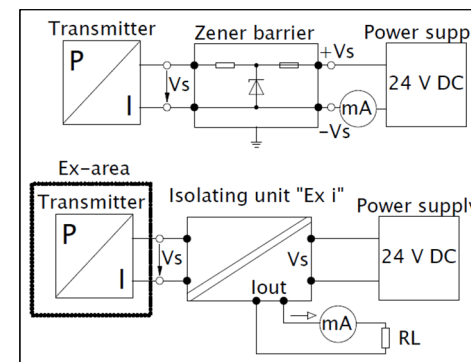



Fig. 3 Circuit diagrams

 Please pay attention to item (17) of the type examination certificate, which stipulates special conditions for intrinsically safe operation.

5.4 Exemplary circuit description

The supply voltage of e. g. 24 V_{DC} provided by the power supply is led across the Zener barrier. The Zener barrier contains series resistances and Zener diodes as protective components. Subsequently, the operating voltage is applied to the device and, depending on the pressure a particular signal current will flow.

 **DANGER!** When installing the intrinsically safe device as a zone-0-equipment, the supplying must be carried out by a power supply which must be galvanically insulated and which is not allowed to be grounded.

5.5 Functional selection criteria for Zener barriers and galvanic power supply

The minimum supply voltage V_{S min} of the device must not fall short since a correct function of the device can otherwise not be guaranteed. The minimum supply voltage has been defined in the respective product-specific data sheet under "Output signal / Supply".

When using a galvanically insulated amplifier with a linear bonding, please attend that the terminal voltage of the device will decrease like it does with a Zener barrier. Furthermore, it has to be attended that the supply of the device will also decrease with an optionally used signal amplifier.

5.6 Test criteria for the selection of the Zener barrier

In order not to fall below V_{S min}, it is important to verify which minimum supply voltage is available at full level control of the device. Full level control, i. e. a maximum or nominal output signal (20 mA), can be reached by applying the maximum physical input signal (pressure).

The technical data of the barrier will usually provide the information needed for the selection of the Zener barrier. However, the value can also be calculated. If a maximum signal current of 0.02 A is assumed, then – according to Ohm's law – a particular voltage drop results on the series resistance of the Zener barrier. This voltage drop is subtracted from the voltage of the power supply and as a result, the terminal voltage is obtained which is applied on the device at full level control. If this voltage is smaller than the minimum supply voltage, another barrier or a higher supply voltage should be chosen.

 Please pay attention when choosing the barrier or the transmitter repeater because some supplied devices / Zener barriers are not suitable for HART[®] communication. Most manufacturers offer a device group especially developed for this application.

 When selecting the ballasts, the maximum operating conditions according to the EC type-examination certificate must be observed. When assessing these, refer to their current data sheets to ensure that the entire interconnection of intrinsically safe components remains intrinsically safe.

6. Electrical Installation

 **WARNING!** Install the device in currentless environments only!

 **WARNING!** Install the connection for devices equipped with terminal clamps so that the separating spaces comply with the standard and the connecting lines cannot be loosened.

 By devices with pressure flameproof enclosure a cable gland M20x1.5 with the name HSK-M-Ex-d is prescribed. This is already premounted.

 **DANGER!** Danger of explosion when surpassing the maximum supply of 28 V_{DC}!

 **NOTE** – The cap for the connection clamps and display can be opened only if a locking protection, headless screw with inside hexagonal, remove became. The screw is on the right side below the cap. After attach of the cap for display and for the connection clamps, the locking protection must be screwed again purely. Besides, the lubrication of the thread ways is not necessary.

 **NOTE** - The cable gland by devices with flameproof enclosure is suitable only for the firm transfer!

Establish the electrical connection of the device according to the technical data shown on the manufacturing label, the following table and the wiring diagram.

Pin configuration:

Electrical connections	Terminal clamps in clamping chamber with cable gland M 20 x 1,5 (for cable Ø 5 up to 14 mm)
Supply +	+
Supply -	-
Test COM / Test - COM	TEST+ COM/TEST-COM
Shield	Shield

Wiring diagram:

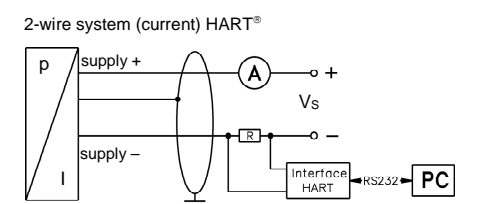

ensure that the cords are not turned or squeezed. Before screwing on the cap again, the o-ring and sealing surfaces of the housing have to be checked for damage and if necessary to be changed! Afterwards screw the metal cap on by hand and make sure that the field housing is firmly locked again.

8. Operation

8.1 Display- and operating modul

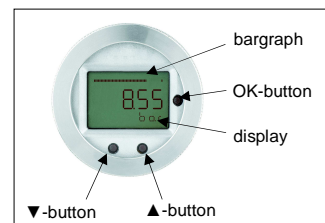

Fig. 4 touch pad

A bargraph is shown in the display, indicating the current pressure input as percentage of the specified pressure range. The indication of the measured value as well as the configuration of the individual parameters occurs through a menu via the display. The individual functions can be set with the help of three miniature push buttons located under the metal cap. For XMP is additionally the possibility given to operate via three push buttons (accessible from above). This is especially an advantage in IS-areas, caused by the fact that the device can be configured in situ without opening the operating and display module. Therefore the metal plate (on the top side of the device), has to be folded backwards after loosening the right screw. The definition of the three buttons is: ▼, OK, ▲ (starting at the left side).

The menu system is a closed system allowing you to scroll both forward and backward through the individual set-up menus to navigate to the desired setting item. All settings are permanently stored in a Flash EPROM and therefore available even after disconnecting from the supply voltage.

WARNING! It is prohibited to open and configure the devices in the presence of explosion hazards. After configuration it must be ensured that the device is completely closed again outside the explosion hazard area.

! Pay attention that no moisture can enter the device during configuration. Moreover, the seals and the sealing surfaces should not get dirty, as this may cause a reduction of the degree of protection depending on the case of application or place of installation. This can lead to a breakdown of the device or to irreparable damages on the device. Right after configuration, the metal cap has to be screwed on again.

8.2 Structure of the menu system

See arranged supplementary sheet (supplementary sheet / structure of the menu system). This supplementary sheet should only be used with this operating manual.

8.3 Menu list

- **▲-button:** with this button you move forward in the menu system or increase the displayed value; it will also lead you to the operating mode (beginning with menu item "1 DISPLAY")
- **▼-button:** with this button you move back in the menu system or decrease the displayed value; it will also lead you to the operating mode (beginning with menu item "5 SERVICE")
- **OK-button:** with this button menu items and set values have to be confirmed

execution of configuration:

- set the desired menu item by pushing the ▲- or ▼-button
- activate the set menu item by pushing the OK-button
- set the desired value or select one of the offered settings by using the ▲- or ▼-button
- store/confirm the set value/selected setting and exit the menu by pushing the OK-button.

! If a parameter is configurable by a value, each digit may be configured separately. That means after activating such a menu item (e. g. "2.3.1 OFFSET") by pushing the OK-button, the first digit of the currently set value will start to blink. Now scroll up or down to the desired digit via the ▼- or ▲-button and confirm it with the OK-button. After that, the next digit will start to blink. Configure it in the same way. In the menu items "2.3.1 OFFSET" and "2.3.2 FINALVAL", the decimal point will then start to blink and it is also possible to change its position by using the ▼- or ▲-button. By confirming the position with the OK-button, the total value will be stored if permissible. If the value is out of range, an error message (e. g. Error 03) will appear in the display and the set value will **not** be stored. If you intend to set a negative value, the first digit has to be configured with the ▼-button.

1 DISPLAY	Display
1.1 P _{max}	Maximum pressure display (high pressure) The maximum pressure applied during measuring is shown in the display.
1.2 P _{min}	Minimum pressure display (low pressure) The minimum pressure applied during measuring is shown in the display.
1.3 T _{max}	Maximum temperature display (high temperature) The minimum temperature during measuring is shown in the display.
1.4 T _{min}	Minimum pressure display (high pressure) The maximum pressure applied during measuring is shown in the display.
1.5 CLEAR	Use to clear the values 1.1-1.4 (P _{max} , P _{min} , T _{max} , T _{min})
1.6 INFO	Setting of the display meaning of the permissible numbers: "1": 1. line: measured pressure 2. line: set pressure unit "2": 1. line: output signal 2. line: mA "3": 1. line: measured temperature 2. line: °C "4": 1. line: measured pressure 2. line: changes between set pressure unit / output signal in mA "5": 1. line: measured pressure 2. line: changes between set pressure unit / measured temperature in °C "6": 1. line: measured pressure 2. line: changes between set pressure unit / output signal in mA / measured temperature in °C
2 CALIB	Calibration
2.1 ZERO	Offset correction By choosing the submenu 2.1 with the OK-button, „CONFIRM“ appears in the display. By pushing the OK-button for at least 2 seconds, the correction is carried out and „CONFIRM“ disappears in the display.
2.2 CAL REF	Calibration reference
2.2.1 OFFSET	Offset calibration After feeding and adoption of reference value, choose the submenu 2.2.1 with the OK-button, „CONFIRM“ appears in the display. By pushing the OK-button for at least 2 seconds, the calibration is carried out and „CONFIRM“ disappears in the display.
2.2.2 FINALVAL	Final value calibration After feeding and adoption of reference value, choose the submenu 2.2.2 with the OK-button, „CONFIRM“ appears in the display. By pushing the OK-button for at least 2 seconds, the calibration is carried out and „CONFIRM“ disappears in the display.
2.3 ADJUST	Adjust
2.3.1 OFFSET	Setting of the initial value of the measuring range With button ▲ and ▼ you can set a initial value of measuring range. The value of new range is max. 1:10 of original measuring range.
2.3.2 FINALVAL	Setting of the terminal value of the measuring range With button ▲ and ▼ you can a terminal value of measuring range. The value of new range is max. 1:10 of original measuring range.
2.3.3 Z-CORR	Resetting the offset By choosing the submenu 2.3.3 with the OK-button, „CONFIRM“ appears in the display. By pushing the OK-button for at least 2 seconds, the resetting is carried out and „CONFIRM“ disappears in the display.
3 SIGNAL	Signal
3.1 FUNKTION	Function selection e.g. "LINEAR" (linear function)
3.2 DENSITY	Input the density [kg/m ³]. The unit will be changed to [mFs]
3.3 DAMP	Setting of the damping permissible range: from 0 up to 100 sec
3.4 SIMULAT	Free input of output signal [mA] for simulation of plant conditions (from 3.8 ... 21.6 mA)
4 SETTINGS	Settings
4.1 DISPLAY	Extension of display
4.1.1 UNIT P	Setting of the pressure unit permissible units: bar, mbar, g/cm ² , kg/cm ² , Pa, kPa, Torr, atm, mmWS (mm H2O), mmHg, PSI, FIH ₂ O FIH ₂ O- feat H ₂ O 20°C ! a conversation of all pressure related parameters is carried out automatically
4.1.2 UNIT T	Setting of the temperature unit Switching between the unit [°C], [°F] and [K]
4.2 HART-ID	HART-ID (only for HART[®]- devices with multidrop-mode to adjust) HART-ID (only with HART [®] - to put to devices in the multi drop mode) Put the desired ID No. (between "0 and 15") and confirm this with the OK-button. A configuration of this number is only necessary if you liked to pursue the device in the multi drop mode (connection of several HART [®] devices). If the ID No. on "0" is put, the multi drop mode is deactivated and the pressure transmitter works in the analogous mode.
4.3 USER-L	Configuration of the access protection For security reasons, it is necessary to enter the password before configuring the access protection. Confirm it with the OK-button. The default setting for the password is "0000". meaning of the permissible numbers: "0": the complete menu system is unlocked "1": following menus are unlocked: 1 DISPLAY, 3 SIGNAL, 4.3 USER-L "2": following menus are unlocked: 1 DISPLAY, 4.3 USER-L
4.4 PASSW	Configuration of the password For security reasons, it is necessary to enter the current password before the configuration of the new one. Confirm with the OK-button. The default setting for the password is "0000". Then set the new password and confirm with the OK-button.
4.5 LANGUAGE	Choosing of user language [DE] or [EN]
5 SERVICE	Service
5.1 FACTORY	To restore to factory settings
5.2 ERR CURR	Error current limits Setting of the error current limit value: 21.6 mA or 3.8 mA
5.3 TYPE	Displaying of the type of device
5.4 SER-NO	Displaying of the serial number
5.5 VERS	Displaying of the program version

9. Error handling

9.1 Error messages

PASSED PARAMETER TOO SMALL	passed parameter value is too small
PASSED PARAMETER TOO LARGE	passed parameter value is too large
LOOP CURRENT NOT ACTIVE	loop current is not active (HART ID > 0, device work in mode Multidrop)
APPLIED PROCESS TOO LOW	applied process is too low
APPLIED PROCESS TOO HIGH	applied process is too high
LOWER RANGE VALUE TOO HIGH	lower range value (OFFSET) is too high
LOWER RANGE VALUE TOO LOW	lower range value (OFFSET) is too low
UPPER RANGE VALUE TOO HIGH	upper range value (FINALVAL) is too high
UPPER RANGE VALUE TOO LOW	upper range value (FINALVAL) is too low
SPAN TOO SMALL	span too small

Malfunction	Possible cause	Error detection / corrective
display does not work	falsely connected	inspect the connections
	line break	inspect all connecting lines of the device (including the connector plugs)
	defective energy supply	inspect the power supply and the applied supply voltage at the transmitter
no output signal	wrong connected	inspect the connection
	line break	inspect all line connections necessary to supply the device (including the connector plugs)
	defective amperemeter (signal input)	inspect the amperemeter (fine-wire fuse) or the analogue input of the PLC
analogue output signal too low	load resistance too high	verify the value of the load resistance
	supply voltage too low	verify the output voltage of the power supply
	defective energy supply	inspect the power supply and the applied supply voltage at the device
small shift of output signal	diaphragm is highly contaminated	careful cleaning with non-aggressive cleaning solution and a soft brush or sponge; incorrect cleaning can cause irreparable damages on diaphragm or seals
	diaphragm is calcified or coated with deposit	if possible it is recommended to send the device to BD SENSORS for decalcification or cleaning
large shift of output signal	diaphragm is damaged (caused by overpressure or manually)	check the diaphragm; if it is damaged, please send the device to BD SENSORS for repair
measured value (display and analogue output) deviates from the nominal value	high pressure / pressure peaks	a recalibrated or replaced of the pressure port by BD SENSORS is necessary
	mechanical damage to diaphragm	
constant output signal at 4 mA	wrong ID-number	ensure in the menu item "ID" that the set value for the ID-number is "0000"

If you detect an error, please try to eliminate it by using this table or send the device to our service address for repair.

DANGER! Working on supplied (active) parts, except for intrinsically safe circuits, is principally prohibited during an explosion hazard. Additionally, the operator is obligated to observe the information concerning operation and maintenance work on the warning signs possibly affixed to the device.

! Improper action and opening can damage the device. Therefore repairs on the device may only be executed by the manufacturer!

10. Placing out of service

WARNING! Disassemble the device only in current and pressure less condition! Check before disassembly, if it is necessary to drained off the media before dismantling!

WARNING! Depending on the medium, it may cause danger for the user. Comply therefore with adequate precautions for purification.

11. Maintenance

In principle, this device is maintenance-free. If desired, the housing of the device can be cleaned when switched off using a damp cloth and non-aggressive cleaning solutions.

Depending on the measuring medium, however, the diaphragm may be polluted or coated with deposit. If the medium is known for such tendencies, the user has to set appropriate cleaning intervals. After placing the device out of service correctly, the diaphragm can usually be cleaned carefully with a non-aggressive cleaning solution and a soft brush or sponge. If the diaphragm is calcified, it is recommended to send the device to BD SENSORS for decalcification. Please read therefore the chapter "Repair" below.

! An incorrect cleaning can cause irreparable damages on the diaphragm. Never use spiky objects or pressured air for cleaning the diaphragm.

12. Service/Repair

12.1 Recalibration

During the life-time of a transmitter, the value of offset and span may shift. As a consequence, a deviating signal value in reference to the nominal pressure range starting point or end point may be transmitted. If one of these two phenomena occurs after prolonged use, a recalibration is recommended to ensure furthermore high accuracy.

12.2 Return

Before every return of your device, whether for recalibration, decalcification, modifications or repair, it is necessary to contact us to ensure a fast handling of your request. Please inform us by sending an email to: sale@bdsensors.cz. Include the number of devices sent and request a RMA. Then clean the device and pack it shatterproof before send it to BD SENSORS indicating the RMA.

13. Disposal

The device must be disposed according to the European Directives 2002/96/EC and 2003/108/EC (on waste electrical and electronic equipment). Waste of electrical and electronic equipment may not be disposed by domestic refuse!

WARNING! Depending on the measuring medium, deposit on the device may cause danger for the user and the environment. Comply with adequate precautions for purification and dispose of it properly.

14. Warranty conditions

The warranty conditions are subject to the legal warranty period of 24 months from the date of delivery. In case of improper use, modifications of or damages to the device, we do not accept warranty claims. Damaged diaphragms will also not be accepted. Furthermore, defects due to normal wear are not subject to warranty services.

15. Declaration of conformity / CE

The delivered device fulfills all legal requirements. The applied directives, harmonised standards and documents are listed in the EC declaration of conformity, which is available online at www.bdsensors.com. Additionally, the operational safety is confirmed by the CE sign on the manufacturing label.