

Operating Manual



Probe LMK / LMP for IS-Areas

**DX4-LMK 358, DX4-LMK 382, DX4B-LMK387,
DX5A-LMK 358H, DX5A-LMK 382H
DX9-LMK 307, DX9-LMP 307, DX9-LMP 307i,
DX9-LMP 308, DX9-LMP 308i**



www.bdsensors.cz

BA_TS_EX_E_SRO

Headquarter Eastern Europe

BD SENSORS s.r.o.
Hradištská 817
CZ - 687 08 Buchlovce
Czech Republic
Tel.: +420 572 411 011
Fax: +420 572 411 497

Headquarter Western Europe / International

BD SENSORS GmbH
BD-Sensors-Str. 1
D - 95199 Thierstein
Germany
Tel.: +49 (0) 92 53 / 98 11-0
Fax: +49 (0) 92 53 / 98 11-11

Russia

BD SENSORS RUS
39a, Varshavskoe shosse
RU - Moscow 117105
Russia
Tel.: +7 (0) 9 59 81 / 09 63
Fax: +7 (0) 9 57 95 / 07 21

further agencies in:

EUROPE

- Belgium
- Denmark
- Finland
- France
- Great Britain
- Greece
- Italy
- Lithuania
- Luxemburg
- Netherlands
- Norway
- Poland
- Portugal

- Romania
- Sweden
- Switzerland
- Slovakia
- Spain
- Turkey
- UK
- Ukraine

AFRICA

- Egypt
- South Africa

ASIA

- India
- Iran
- Israel
- Japan
- Kazakhstan
- Malaysia
- Singapore
- Taiwan
- Thailand
- Vietnam

AUSTRALIA

The addresses of our distribution partners are listed on our homepage www.bdsensors.com. It is possible to download data sheets, operating manuals, ordering codes and certificates, as well.

Table of contents

- General information
- Product identification
- Mechanical installation
- Special regulations for IS-areas
- Electrical Installation
- Characteristic
- Initial start-up
- Placing out of service
- Maintenance
- Service / Repair
- Disposal
- Warranty conditions
- Declaration of conformity / CE
- Explanation to the EC type-examination certificate
- Error handling

1. General information

1.1 Information on the operating manual

This operating manual contains important information on proper usage of the device. Read this operating manual carefully before installing and starting up the pressure measuring device.

Adhere to the safety notes and operating instructions which are given in the operating manual. Additionally applicable regulations regarding occupational safety, accident prevention as well as national installation standards and engineering rules must be complied with!

For the installation, maintenance and cleaning of the device, you must absolutely observe the relevant regulations and stipulations on explosion protection (VDE 0160, VDE 0165 and EN 60079-14) as well as the occupational safety provisions.

DX4/DX4B/DX5A/DX9: EN60079-0:2012
EN60079-11:2012
EN60079-26:2015

This operating manual is part of the device, must be kept nearest its location, always accessible to all employees.

This operating manual is copyrighted. The contents of this operating manual reflect the version available at the time of printing. It has been issued to our best knowledge. However, errors may have occurred. BD SENSORS is not liable for any incorrect statements and their effects.

– Technical modifications reserved –

1.2 Symbols used

⚠ DANGER! – dangerous situation, which may result in death or serious injuries

⚠ WARNING! – potentially dangerous situation, which may result in death or serious injuries

⚠ CAUTION! – potentially dangerous situation, which may result in minor injuries

! CAUTION! – potentially dangerous situation, which may result in physical damage

🔧 NOTE – tips and information to ensure a failure-free operation

1.3 Target group

⚠ WARNING! To avoid operator hazards and damages of the device, the following instructions have to be worked out by qualified technical personnel.

1.4 Limitation of liability

By non-observance of the operating manual, inappropriate use, modification or damage, no liability is assumed and warranty claims will be excluded.

1.5 Intended use

The probes have been developed for continuous level measurement. This operating manual applies to devices with explosion protection approval and is intended for the use in IS-areas. A device has an explosion protection approval if this has been specified in the purchase order and confirmed in our order confirmation. In addition, the manufacturing label contains the -symbol.

It is the operator's responsibility to check and verify the suitability of the device for the intended application. If any doubts remain, please contact our sales department in order to ensure proper usage. BD SENSORS is not liable for any incorrect selections and their effects!

Permissible media are gases or liquids (no solids and frozen media), specified in the data sheet. In addition it has to be ensured, that this medium is compatible with the media wetted parts.

The technical data listed in the current data sheet are engaging and must be complied with. If the data sheet is not available, please order or download it from our homepage. (<http://www.bdsensors.com>)

⚠ WARNING! – Danger through improper usage!

⚠ WARNING! - Freely hanging submersible probe with FEP cable must not be used in cases where the electrostatic charging of the material and this charged material might come into contact with the cable (eg. pneumatic transport, mining belts, fast moving or mixing of suspensions, coil up the foils, removing the films or foils from the smooth surface etc.).

1.6 Safety technical maximum values

Depending on the type of the device, different approvals are valid. The designation of the approval (DX3, DX4, DX5, DX5A or DX9) to match up with the following values is written on the manufacturing label under type designation.

Permissible temperatures of environment are specified in the current data sheet.

DX4: $U_i = 28 \text{ V}$; $I_i = 93 \text{ mA}$; $P_i = 660 \text{ mW}$; $C_i = 27 \text{ nF}$;
 $L_i = 5 \text{ }\mu\text{H}$ plus line inductances of $1 \text{ }\mu\text{H/m}$ and line capacities of 100 pF/m

Range of ambient temperature
Use in zone 0 ($p_{\text{atm}} 0.8 \text{ bar}$ to 1.1 bar): $-20 \dots 60 \text{ }^\circ\text{C}$
Use in zone 1: $-25 \dots 70 \text{ }^\circ\text{C}$;

DX4B: $U_i = 28 \text{ V}$; $I_i = 93 \text{ mA}$; $P_i = 660 \text{ mW}$; $C_i = 49.2 \text{ nF}$;
 $L_i = 0 \text{ }\mu\text{H}$; with respect to the housing, the supply connections have an interior capacity of max. 100 nF

Range of ambient temperature
Use in zone 0 ($p_{\text{atm}} 0.8 \text{ bar}$ to 1.1 bar): $-20 \dots 60 \text{ }^\circ\text{C}$
Use in zone 1: $-25 \dots 65 \text{ }^\circ\text{C}$;

DX5: $U_i = 28 \text{ V}$; $I_i = 93 \text{ mA}$; $P_i = 660 \text{ mW}$; $C_i = 13.2 \text{ nF}$;
 $L_i = 0 \text{ mH}$ plus line inductances of $1 \text{ }\mu\text{H/m}$
and line capacities of 160 pF/m ; CiGND = 27 nF

Range of ambient temperature
Use in zone 0 ($p_{\text{atm}} 0.8 \text{ bar}$ to 1.1 bar): $-20 \dots 60 \text{ }^\circ\text{C}$
Use in zone 1: $-25 \dots 70 \text{ }^\circ\text{C}$;

DX19: $U_i = 28 \text{ V}$, $I_i = 93 \text{ mA}$, $P_i = 660 \text{ mW}$, $C_i = 0 \text{ nF}$, $L_i = 0 \text{ }\mu\text{H}$
plus line inductances of $1 \text{ }\mu\text{H/m}$ and line capacities of 160 pF/m (with factory-supplied cable); with respect to the housing, the supply connections have an interior capacity of max. 27 nF

Range of ambient temperature: $-20 \dots 70 \text{ }^\circ\text{C}$
for type DX19-*** i: $-20 \dots 65 \text{ }^\circ\text{C}$

Use in zone 0 ($p_{\text{atm}} 0.8 \text{ bar}$ to 1.1 bar): $-20 \dots 60 \text{ }^\circ\text{C}$

1.7 Package contents

Please verify that all listed parts are undamaged included in the delivery and check for consistency specified in your order:

- probe
- this operating manual
- with option SIL2 version: Functional Safety Manual, Functional Safety Data Sheet[®], SIL Declaration of Conformity

2. Product identification

The device can be identified by its manufacturing label. It provides the most important data. By the ordering code the product can be clearly identified.

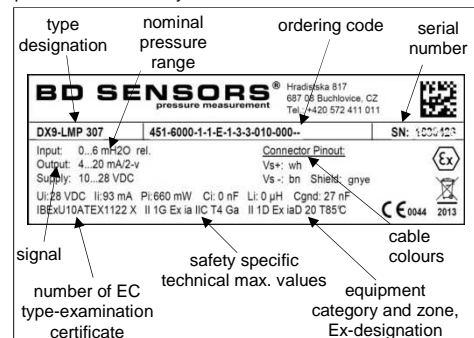

Fig. 1 manufacturing label – for DX9

! The manufacturing label must not be removed from the device!

3. Mechanical installation

3.1 Mounting and safety instructions

	<ul style="list-style-type: none"> Explosion hazard, airborne parts, leaking fluid, electric shock Always mount the device in a depressurized and de-energized condition!
	<ul style="list-style-type: none"> Explosion hazard due to high-charging processes in connection with free-hanging probes with cable FEP Fixed installation of the FEP cable!

⚠ WARNING! Install the device only when depressurized and currentless!

⚠ WARNING! This device may only be installed by qualified technical personnel who has read and understood the operating manual!

⚠ DANGER! Caused by the explosion hazard following instructions have to be complied with:

- The technical data listed in the EC type-examination certificate are engaging and must absolutely be complied with. If the certificate is not available, please order or download it from our homepage: <http://www.bdsensors.com/products/download/certificates>
- Working on supplied (active) parts, except for intrinsically safe circuits, is principally prohibited during an explosion hazard.
- Make sure that an equipotential bonding is in place for the entire course of the line, both inside and outside the intrinsic area.
- In case of increased danger of lightning strike or damage by overvoltage, a stronger lightning protection should be planned.
- Observe the limiting values specified in the EC type-examination certificate. (Capacitance and

inductance of the connection cable are not included in the values.)

- Make sure that the entire interconnection of intrinsically safe components remains intrinsically safe. The operator is responsible for the intrinsic safety of the overall system (installation of intrinsic parts).
- Do not mount the device in a pneumatic flow rate!
- The probe must be installed in such a way that rubbing or impact of the sensor head (sensor element), e.g. against a tank wall, is prevented. It is also important to consider the operating conditions such as flow conditions. This applies especially to probes with cable outlet and devices with a pipe extension with a length of more than 2.8 m .
- Excessive dust deposits (over 5 mm) and a complete dust covering must be avoided for flange version of LMK 382 and LMK 382 H!

! Handle this high-sensitive electronic precision measuring device with care, both in packed and unpacked condition!

! There are no modifications/changes to be made on the device.

! Do not throw the package/device!

! To avoid damaging the diaphragm, remove packaging and protective cap directly before starting assembly. The delivered protective cap has to be stored!

! Place the protective cap on the pressure port again immediately after disassembling.

! Handle the unprotected diaphragm very carefully - it is very sensitive and may be easily damaged.

! Do not use any force when installing the device to prevent damage of the device and the plant!

! When placing the device into operation or after maintenance work, the probe has to be submerged slowly into the medium! A rough immersion into the medium can damage or destroy the diaphragm.

3.2 Installation steps for probe

NOTE – Always immerse the device slowly into the fluid to be measured! If the probe strikes the liquid surface, the diaphragm could be damaged or destroyed.

NOTE – Fasten the probe properly according to your requirements.

NOTE – WARNING - Freely hanging submersible probe with FEP cable must not be used in cases where the electrostatic charging of the material and this charged material might come into contact with the cable (eg. pneumatic transport, mining belts, fast moving or mixing of suspensions, coil up the foils, removing the films or foils from the smooth surface etc.).

🔧 As standard, the probe is supplied without fastening material. Clamp fixing, anchor clamp and mounting flanges are available as accessories, for different mounting variants.

3.3 Installation steps for flange version (LMK 382 / LMK 382 H)

– Carefully remove the pressure measuring device from the package and dispose of the package properly.

– Please ensure that the mounting thread is clean and free of damage.

– Check to ensure that the O-ring fits properly in the groove.

– Screw in the mounting thread of the transmitter in the transmitter flange.

– Next, tighten it by an open-end wrench. (approx. 25 Nm)

– Install the flange according to your demands.

🔧 If a new transmitter flange is needed, it can be ordered from BD SENSORS.

3.4 Removing the protection cap (if existing)

For the protection of the diaphragm, some of the probes have a plugged-on protection cap. If the device shall be used in high-viscosity media such as sludge, a removal of the cap before start-up is necessary. Thus, the sensor becomes flush and the medium will attain quickly to the diaphragm.

🔧 If it is necessary for your application to remove the protection cap, this has to be done with utmost care. To prevent a damage of the diaphragm, please follow these instructions.

Removal by hand

– Hold the probe in a way that the protection cap points upwards.

– Hold the probe with one hand on the sensor section (1).

– Remove the protection cap (2) with the other hand.

Removal with a tool (recommended)

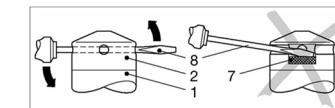

Fig. 2 removal of protection cap

– Hold the probe in a way that the protection cap points upwards.

– Slide a small tool such as a screwdriver (8) straight through two opposite drill holes in the protective cap (2).

– Lever it off by moving up the handle of the screwdriver.

🔧 Make sure that the sensor (7) under the protection cap will not be damaged!

3.5 Cable protection (optional)

On order, the probe has been delivered with cable protection; if the device has optionally been prepared for mounting with stainless steel or PVC pipe, a suitable cable protection has to be mounted by the customer.

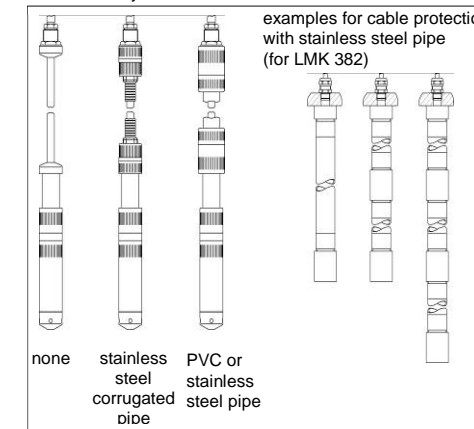

Fig.3 versions of cable protection

4. Special regulations for IS-areas

4.1 Protection against electrostatic charge hazards

Different types of probes partially consist of chargeable plastic components. These are, in particular, the carrying and connection cables, terminal boxes as well as housing enclosures. A potential electrostatic charge presents the danger of spark generation and ignition. An electrostatic charge must therefore be absolutely prevented.

🔧 Generally, a shielded cable must be used.

🔧 Avoid friction on the plastic surfaces!

🔧 Do not clean the device dry! Use, for example, a damp cloth.

The following warning sign is, if applicable, attached to the probe. It points once more to the hazard of electrostatic charging.

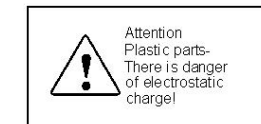

Fig. 4 warning sign

! The warning sign must not be removed from the device!

4.2 Overvoltage protection

If the device is used as electrical equipment of category 1 G, then a suitable overvoltage protection device must be connected in series (attend the valid regulations for operating safety as well as EN60079-14).

4.3 Schematic circuit

The operation of an intrinsically safe probe in intrinsic safe areas requires special care when selecting the necessary Zener barrier or probe repeater devices to be able to use the device's characteristics to the full extent. The following diagram shows a typical arrangement of power supply, Zener barrier and probe.

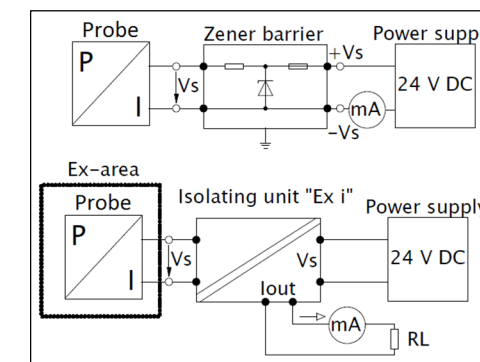

Fig. 5 circuit diagrams

! Please pay attention to item (17) of the type examination certificate, which stipulates special conditions for intrinsically safe operation.

4.4 Exemplary circuit description

The supply voltage of e.g. 24 V_{DC} provided by the power supply is led across the Zener barrier. The Zener barrier contains series resistances and breakdown diodes as protective components. Then the operating voltage is applied to the probe and, depending on the pressure, a particular signal current will flow.

⚠ When installing the intrinsically safe device as a zone-0 equipment, the supplying must be carried out by a probe repeater device which must be galvanically insulated and which is not allowed to be grounded (compare Fig. 5).

4.5 Functional selection criteria for Zener barriers and galvanic power supply

The minimum supply voltage $V_{S \text{ min}}$ of the probe must not fall short since a correct function of the device can otherwise not be guaranteed. The minimum supply voltage has been defined in the respective product-specific data sheet under "Output signal / supply".

When using a galvanically insulated amplifier with linear bonding, please note that the terminal voltage of the probe will decrease like it does with a Zener barrier. Furthermore, you will have to attend that the supply will also decrease with an optionally used signal amplifier.

4.6 Test criteria for the selection of the Zener barrier

In order not to fall below $V_{S \text{ min}}$, it is important to verify which minimum supply voltage is available at full level control of the probe. Full level control, i.e. a maximum or nominal output signal (20 mA), can be reached by applying the maximum physical input signal (pressure).

The technical data of the barrier will usually provide you with the information needed for the selection of the Zener barrier. However, the value can also be calculated. If a maximum signal current of 0.02 A is assumed, then – according to Ohm's law – a particular voltage drop will result on the series resistance of the Zener barrier. This voltage drop is subtracted by the voltage of the power supply and as a result, the terminal voltage is obtained which is applied on the probe at full level control. If this voltage is smaller than the minimum supply voltage, another barrier or a higher supply voltage should be chosen.

Please pay attention when choosing the barrier or the probe repeater because some supplied devices / Zener barriers are not suitable for HART® communication. Most manufacturers offer a device group especially developed for this application.

When selecting the supplied devices / Zener barriers, the maximum operating conditions according to the EC type-examination certificate must be observed. When assessing these, refer to their current data sheets to ensure that the entire interconnection of intrinsically safe components remains intrinsically safe.

4.7 Calculation example for the selection of the Zener barrier

The nominal voltage of the power supply in front of the Zener barrier is 24 V_{DC} ± 5 %. This results in:

- greatest supply voltage: $V_{Sup\ max} = 24\ V \cdot 1.05 = 25.2\ V$

- smallest supply voltage: $V_{Sup\ min} = 24\ V \cdot 0.95 = 22.8\ V$

The series resistance of the Zener barrier is listed with 295 ohm. The following values must still be calculated:

- Voltage drop at the barrier (with full conduction):
 $V_{ab\ barrier} = 295\ \Omega \cdot 0.02\ A = 5.9\ V$

- Terminal voltage at the probe with Zener barrier:
 $V_{KI\ TS} = V_{Sup\ min} - V_{ab\ barrier} = 22.8\ V - 5.9\ V = 16.9\ V$

- Minimum supply voltage of the probe, e. g. LMK 351 (according to data sheet):
 $V_{KI\ TS\ min} = 12\ V_{DC}$ (corresponding to $V_{B\ TS\ min}$)

Condition:

$$V_{KI\ TS} \geq V_{KI\ TS\ min}$$

Result:

The terminal voltage of the probe with Zener barrier lies at 16.9 V and is therefore higher than the minimum supply voltage of the probe which lies at 12 V_{DC}. This means, the Zener barrier has been selected correctly regarding the supply voltage.

Note that no line resistances have been listed in this calculation. However, these will lead to an additional voltage drop that must be taken into account.

5. Electrical Installation

WARNING! Install the device only when currentless!

DANGER! Danger of explosion when surpassing the maximum supply of 28 V_{DC}!

Establish the electrical connection of the device according to the technical data shown on the manufacturing label, the following table and the wiring diagram.

Pin configuration:

Electrical connections	cable colours
Supply +	wh (white)
Supply -	bn (brown)
Shield	ye/gn (yellow / green)

Wiring diagrams:

2-wire-system (current)

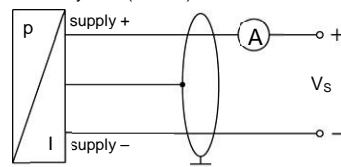

2-wire-system (current) HART®

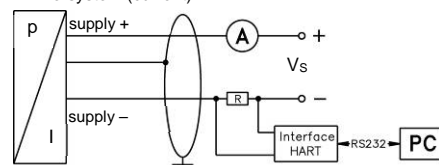

A minimum static bending radius has to be complied with. For static installation use the 10-fold cable diameter, for dynamic applications use the 20-fold diameter.

Prevent the damage or removal of the PTFE filter which is fixed over the end of the air tube on devices with cable outlet and integrated air tube.

! For a clear identification, the intrinsically safe cables are marked with light blue shrink tubing (over the cable insulation). If the cable has to be modified (e.g. shortened) and the marking at the cable end has been lost in the process, it must be restored (for example, by marking it again with light blue shrink tubing or an appropriate identification sign).

For the electrical connection a shielded and twisted multicore cable has to be used.

If a transition is desired from a probe cable with gauge tube to a cable without gauge tube, we recommend our terminal box KL 1 or KL 2.

Usually, the required cable is included in the scope of delivery. If it is although necessary to connect an existing or special cable, the total resistance will increase. For applications, where this additional resistance of the connecting cable could cause problems, this cable has to be checked with the following calculation.

$$R_L = \frac{\rho \cdot 2 \cdot l}{A}$$

with R_L : resistance of connecting cable in Ω
 ρ : specific resistance in $\Omega\ mm^2/m$
 l : cable length in m
 A : cross section of conductor in mm^2

$$V_{tot} = (R_{L1} + R_{L2} + \dots + R_{Lmax}) \cdot 0.02\ A$$

with V_{tot} : total voltage drop
 R_{load} : load resistance (to be taken out of the current data sheet)

following condition has to be fulfilled:

$$V_S > V_{tot} + V_{Smin}$$

with V_S : planned supply voltage
 V_{Smin} : minimal supply voltage (to be taken out of the current data sheet)

6. Characteristic

6.1 HART® communication (in H-devices)

! DANGER! It is prohibited to interrupt the intrinsically safe circuit in the presence of explosion hazards in order to loop in a HART® communication interface (HART®-communicator or HART®-modem).

The analogue output signal is overridden by an additional signal according to the HART®-specification. The device can be configured via a HART®-communication device. Therefore we suggest our programming kit CIS 150 (available as accessory). It consists of HART®-modem, connecting cables as well as configuration software and allows a simple and time-saving configuration of all parameters. (The software is compatible with all Windows®-systems from Windows 98 and higher.)

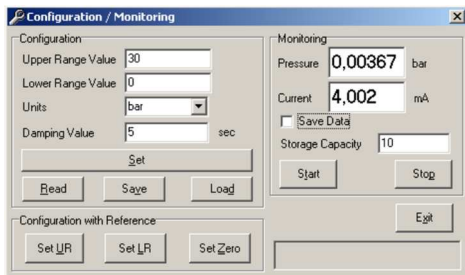

Fig. 6 configurationsoftware

To ensure a trouble-free operation the following requirements should be fulfilled:
 maximal cable length between device and power supply:

$$L_{max} = \frac{65 \cdot 10^6}{R_v \cdot C_v} - \frac{40 \cdot 10^3}{C_v}$$

whereas L_{max} : maximum length of cable in [m]
 R_v : resistance of the cable together with the load resistance in $[\Omega]$
 C_v : capacity of the cable in [pF/m]

resistance R:

$$R = \frac{U - 12}{0.024}\ \Omega$$

whereas U : power supply in [V_{DC}]

The resistance must be at least 240 Ω .

6.2 Separable probes

! DANGER! Separable probes may not be separated while an explosion hazard is present. Transmitter head and cable assembly have to be separated in an area without explosion hazard.

In order to facilitate stock keeping and maintenance, the probe head is plugged to the cable assembly with a connector and can be easily changed. The following probes are separable: LMK 358, LMK 358H, LMP 308 and LMP 308I.

Disassembly

- Hold the probe on the sensor section (2) with one hand and turn the nut (4) carefully to the left with the other hand. Prevent torsion of the cable section (3) against the housing!
- While screwing and pulling off the sensor section (2) from the cable section (3), hold it straight to prevent damages on the plugs.

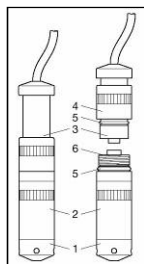

Fig. 7 separability

Assembly

- Check the o-rings (5, 6) and exchange damaged o-rings if necessary.
- Lubricate the radial o-rings (5) with Vaseline or o-ring grease.
- Remove any grease residue from the axial-o-ring (6).
- Plug the cable section (3) straight into the plug of the sensor section (2).
- Hold the probe onto the sensor section (2) with one hand. Screw on and tighten the nut (4) carefully with the other hand. Prevent torsion of the cable section (3) against the housing!

Pin configuration

Electrical connections	Binder series 723 (5-pin)	Binder series 723 (7-pin)
Supply +	3	3
Supply -	1	1
Shield	5	2
RxD	-	4
TxD	-	5
GND	-	7

6.3 Accuracy 0.1 % FSO

Devices with an accuracy of 0.1 % FSO have micro-controlled electronics for processing and improving the signal. As a matter of principle, the processing takes more time than for analogue sensors, which have only an amplifier. Due to this longer response time, the output signal follows the measured value discontinuously. For relatively stable measuring values, this characteristic is secondary. Please compare the specification for the response time in the data sheet.

6.4 Communication interface (i-devices)

Intelligent devices with an optional communication interface can also be configured with these electronics. Offset, span and damping are programmable within the limits given in the data sheet. For configuration, the programming kit CIS 510 consisting of Adapt 1, power supply and Windows® compatible programming software is necessary. This can be ordered as accessory from BD SENSORS.

7. Initial start-up

! WARNING! Before start-up, the user has to check for proper installation and for any visible defects.

! WARNING! The device can be started and operated by authorized personnel only, who have read and understood the operating manual!

! WARNING! The device has to be used within the technical specifications, only (compare the data in the data sheet and the EC type-examination certificate)!

8. Placing out of service

! WARNING! When dismantling the device, it must always be done in the depressurized and currentless condition! Check also if the medium has to be drained off before dismantling!

! WARNING! Depending on the medium, it may cause danger for the user. Comply therefore with adequate precautions for purification.

9. Maintenance

! DANGER! The operator is obligated to observe the information about operation and maintenance work on the warning signs possibly affixed to the device.

In principle, this device is maintenance-free. If desired, the housing of the device can be cleaned when switched off using a damp cloth and non-aggressive cleaning solutions.

Depending on the measuring medium, however, the diaphragm may be polluted or coated with deposit. If the medium is known for such tendencies, the user has to set appropriate cleaning intervals. After placing the device out of service correctly, the diaphragm can usually be cleaned carefully with a non-aggressive cleaning solution and a soft brush or sponge. If the diaphragm is calcified, it is recommended to send the device to BD SENSORS for decalcification. Please read therefore the chapter "Service / Repair" below.

! An incorrect cleaning can cause irreparable damages on diaphragm. Never use spiky objects or pressured air for cleaning the diaphragm.

10. Service / Repair

10.1 Recalibration

During the life-time of a probe, the value of offset and span may shift. As a consequence, a deviating signal value in reference to the nominal pressure range starting point or end point may be transmitted. If one of these two phenomena occurs after prolonged use, a recalibration is recommended to ensure furthermore high accuracy.

10.2 Return

Before every return of your device, whether for recalibration, decalcification, modifications or repair, it has to be cleaned carefully and packed shatter-proofed. You have to enclose a notice of return with detailed defect description when sending the device. If your device came in contact with harmful substances, a declaration of decontamination is additionally required. Appropriate forms can be downloaded from our homepage www.bdsensors.com. Should you dispatch a device without a declaration of decontamination and if there are any doubts in our service department regarding the used medium, repair will not be started until an acceptable declaration is sent.

! If the device came in contact with hazardous substances, certain precautions have to be complied with for purification!

11. Disposal

The device must be disposed according to the European Directives 2002/96/EC and 2003/108/EC (on waste electrical and electronic equipment) (Waste of electrical and electronic equipment may not be disposed by domestic refuse!).



! WARNING! Depending on the measuring medium, deposit on the device may cause danger for the user and the environment. Comply with adequate precautions for purification and dispose of it properly.

12. Warranty conditions

The warranty conditions are subject to the legal warranty period of 24 months from the date of delivery. In case of improper use, modifications or damages to the device, we do not accept warranty claims. Damaged diaphragms will also not be accepted. Furthermore, defects due to normal wear are not subject to warranty services.

13. Declaration of conformity / CE

The delivered device fulfils all legal requirements. The applied directives, harmonised standards and documents are listed in the EC declaration of conformity, which is available online at: <http://www.bdsensors.com>. Additionally, the operational safety is confirmed by the CE sign on the manufacturing label.

14. Explanation to the EC type-examination certificate

To item [12] of the EC type-examination certificate "The marking of the equipment mentioned in [4] must include one of the following details:"

Equipment group				
Explosion protection	II			
Equipment category				
Zone 0 – Gas, vapor, mist	1G			
Zone 1 – Gas, vapor, mist	2G			
Zone 20 - Dust	1D			
Zone 21 - Dust	2D			
Designation according to EN and ignition protection type				
Intrinsically safe design	Ex ia			
Explosion group ¹				
II B		IIB		
II C		IIC		
III C		IIIC		
Temperature class				
max. environmental temperature 85 °C (1G, 2G)			T4	
max. environmental temperature 135 °C (1G, 2G)			T6	
max. surface temperature 85 °C (1D, 2D)			T 85°C	
Ignition protection standard				
Ga				Ga
Da				Da
Gb				Gb
Db				Db

¹ Exact specifications regarding limiting gap width and minimum ignition current ratio can be taken from the corresponding standard or the VDE publication.

15. Error handling

Malfunction	Possible cause	Error detection / corrective
no output signal	wrong connected	inspect the connection
	line break	inspect all line connections necessary to supply the device (including the connector plugs)
	defective ampere meter (signal input)	inspect the ampere meter (fine-wire fuse) or the analogue input of the PLC
analogue output signal too low	load resistance too high	verify the value of the load resistance
	supply voltage too low	verify the output voltage of the power supply
small shift of output signal	defective energy supply	inspect the power supply and the applied supply voltage at the device
	diaphragm is highly contaminated	careful cleaning with non-aggressive cleaning solution and a soft brush or sponge (caution: incorrect cleaning can cause irreparable damages on diaphragm or seals)
large shift of output signal	diaphragm is calcified or coated with deposit	if possible it is recommended to send the device to BD SENSORS for decalcification or cleaning
	diaphragm is damaged (caused by overpressure or manually)	check the diaphragm; if it is damaged, please send the device to BD SENSORS for repair
wrong or no output signal	manually, thermal or chemically damaged cable	check the cable (a possible consequence of a damaged cable is pitting corrosion on the stainless steel housing); please return the device to BD SENSORS for repair

If you detect an error, please try to eliminate it by using this table or send the device to our service address for repair.

! DANGER! Working on supplied (active) parts, except for intrinsically safe circuits, is principally prohibited during an explosion hazard. Additionally, the operator is obligated to observe the information concerning operation and maintenance work on the warning signs possibly affixed to the device.

! Improper action and opening can damage the device. Therefore repairs on the device may only be executed by the manufacturer!